

OCZ

Technology

www.ocztechnology.com

GAME X STREAM POWER SUPPLY

The Ultimate Gamer's PSU that delivers unparalleled high-performance power quietly, reliably, and efficiently to demanding computing environments!



INDEX

Product Features	1
Technical Specifications	2
Outlet Power Connector	3
Safety	3
Short-circuit protection	4
Installation Instructions	4
Safety and EMI	5
Important Warning	5
FAQ's	5

Product Features

1. Intel ATX 2.0: It supports up-to-date ATX 2.0 specification with enhanced compatibility.
2. ATI & nVIDIA support: Independent double +12V design especially for ATI Crossfire & nVidia double graphics cards.
3. AMD support: It supports newest 64 bits CPU by AMD
4. 4 Channel 12V output: It provides a stable electric power output
5. 2 Channel PCI-E connector: It supports double ATI & nVIDIA graphics cards
6. Dual CPU support: It provides 8-pin 12V dual CPU support with stable voltage
7. WEEE & RoHS environmental protection specifications: It accords with WEEE and RoHS by EUROPA
8. High efficiency: power-save and high efficiency (>85%) design
9. Blue baked shell: It's worthy for your collection
10. 12cm light blue fan: 12cm fan design, enhancing the cooling in lower noise
11. Active FPC: environment protected active FPC, enhancing the utilization of energy
12. Full range: AC full range input
13. Low noise: It provides a quiet working environment for you
14. Safety: It has been certified in many countries. The safety is ensured.
15. Over voltage and current protection: A complete protection circuit is implemented, protecting every component in your system
16. 20+4 pin: compatible to all main boards available in the market
17. 4+4 pin: accords with the requirements of CPU in ATX or EPS systems
18. S-ATA: It provides stable power supply for high-speed SATA products
19. High power: 600W,700W & 850W
20. Nylon cover: making the settling easy
21. Smart housing: easy pluggable D-connector
22. Cellular air intake: lower the noise and enhance the cooling air flow

Technical Specifications

Input	Voltage	90Vac ~ 265Vac								
	Frequency	47Hz ~ 63Hz								
	Efficiency	85% typical at full load								
	Power factor	0.99 typical								
OCZGXS600	Voltage	+5V	+12V1	+12V2	+12V3	+12V4	+3.3V	-12V	+5Vsb	
	Current (Min.)	0.5 A	0 A	0 A	0.9 A	0.1 A	0.8 A	0.0 A	0.0 A	
	Current (Max.)	30.0 A	18.0 A	18.0 A	18.0 A	18.0 A	36.0 A	0.5 A	3.0 A	
	Regulation	+/-5%	+/-5%	+/-5%	+/-5%	+/-5%	+/-5%	+/-10%	+/-5%	
	Ripple	50mV	120mV	120mV	120mV	120mV	50mV	120mV	50mV	
	Combine power	+5V and +3.3V total output is 155W max.								
		+3.3V & +5V & +12V1 & +12V2 & +12V3 & +12V4 total output not exceed 580W								
		Total output power is 600W								
Hold up time	17ms min. at 115V/230V & at full load									
OCZGXS700	Voltage	+5V	+12V1	+12V2	+12V3	+12V4	+3.3V	-12V	+5Vsb	
	Current (Min.)	0.5 A	0 A	0 A	0.9 A	0.1 A	0.8 A	0.0 A	0.0 A	
	Current (Max.)	30.0 A	18.0 A	18.0 A	18.0 A	18.0 A	36.0 A	0.5 A	3.0 A	
	Regulation	+/-5%	+/-5%	+/-5%	+/-5%	+/-5%	+/-5%	+/-10%	+/-5%	
	Ripple	50mV	120mV	120mV	120mV	120mV	50mV	120mV	50mV	
	Combine power	+5V and +3.3V total output is 155W max.								
		+3.3V & +5V & +12V1 & +12V2 & +12V3 & +12V4 total output not exceed 680W								
		Total output power is 700W								
Hold up time	17ms min. at 115V/230V & at full load									
OCZGXS850	Voltage	+5V	+12V1	+12V2	+12V3	+12V4	+3.3V	-12V	+5Vsb	
	Current (Min.)	0.5 A	0.5 A	0.5 A	0.5 A	0.5 A	0.8 A	0.0 A	0.0 A	
	Current (Max.)	30.0 A	20 A	20 A	20 A	20 A	30 A	1 A	3.0 A	
	Regulation	+/-5%	+6%/-4%	+6%/-4%	+6%/-4%	+6%/-4%	+/-5%	+/-10%	+/-5%	
	Ripple	50mV	120mV	120mV	120mV	120mV	50mV	120mV	50mV	
	Combine power	+5V and +3.3V total output is 175W max.								
		+3.3V & +5V & +12V1 & +12V2 & +12V3 & +12V4 total output not exceed 825W								
		Total output power is 850W								
Hold up time	17ms min. at 115V/230V & at full load									

Outlet Power connector

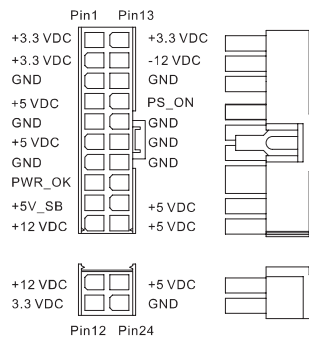

Main power connector

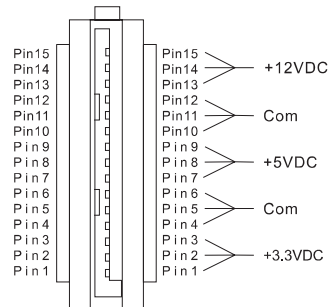

Serial ATA power connector

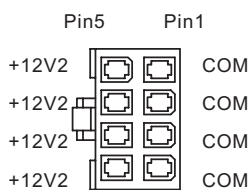

+12V power connector

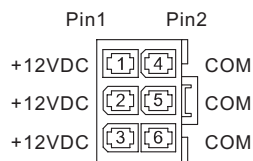

+12V PCI Express Connector

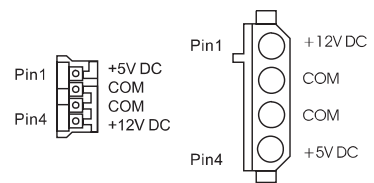

Peripheral power connector

Safety

1. Over-voltage protection

Voltage Source	Protection Point
+3.3V	3.76V-4.8V
+5V	5.6V-7.0V
12VDC	13.5V-16.5V

2. Over-current protection

OUTPUT VOLTAGE	Max. overcurrent limit
+3.3V	55A
+5V	48A
12V1	48A
12V2	
12V3	30A
12V4	30A

Short-circuit protection

Output short circuit is defined to be a short circuit load of less than 0.1 ohm.

In the event of an output short circuit condition on +3.3V, +5V, +12V1, +12V2, +12V3 or 12V4 output, the power supply will shutdown and latch off without damage to the power supply. The power supply shall return to normal operation after the short circuit has been removed and the power switch has been turned off for no more than 2 seconds. In the event of an output short circuit condition on -12V output, the power supply will not be damaged. The power supply shall return to normal operation as soon as the short circuit has been removed, and the power switch has been turned off for no more than 2 seconds.

Installation Instructions

1. Disconnect all power for the computer at the mains
2. Remove the PC case/cover
3. Unplug all power connectors from the old power supply
4. Remove the 4 screws at the rear of the case holding your old power supply to the chassis
5. Screw the 3 screws into the back of the case that will hold the OCZ power supply to the chassis
6. Re-connect all power connectors from the OCZ power supply to the relevant computer components
7. Ensure that there are no screws remaining loose inside the casing to avoid short-circuiting the motherboard
8. Replace the PC case/cover

Safety and EMI

The following has certified the power supply unit:

EMI REGULATORY

- FCC Part 15 Subpart J, Class 'B' 115 Vac operation.
- CISPR 22 Class 'B' 230 Vac operation.

SAFETY

- NEMKO EN 60950-1
- TUV EN60950-1 OR VDE EN60950-1
- CSA-C22.2 NO. 60950-1
- IEC 60950-1
- UL 60950-1
- CE :
 - EN 55022:1998+A1: 2000, Class B
 - EN 61000-3-2: 2000
 - EN 61000-3-3: 1995+A1: 2001
 - CISPR22: 1997+A1: 2000, Class B
 - AS/NZS CISPR 22: 2002, Class B

IMPORTANT WARNING

1. Do not open the top cover of the power supply unit
2. Avoid exposing the power supply to overly-humid conditions

FAQ's

The power supply unit fails to function properly, check the following:

Is the AC input plugged in correctly & is the electrical outlet switched on?

Check that all the output connectors are connected properly to all the components

Disconnect the power cord from the unit in order to reset the power supply unit

If your power supply still does not function correctly, please get in touch with your retailer for repair or replacement

OCZ
Technology
www.ocztechnology.com